

CERTIFIED DIMENSIONAL DRAWINGS

HORIZONTAL DELUXE

LH-D/200 - 1,200 CFM

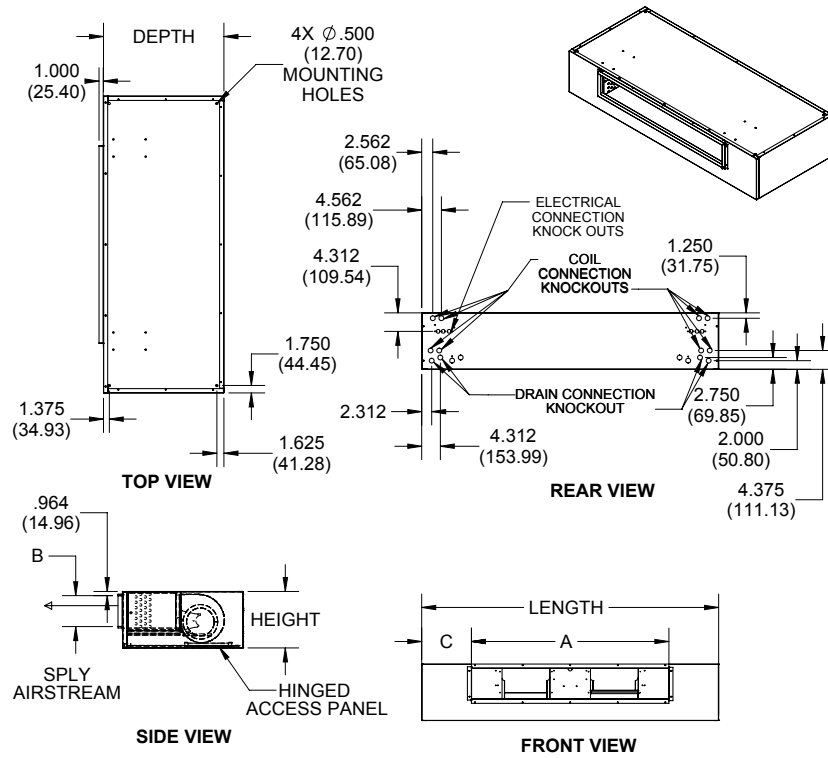

OVERALL				SUPPLY DUCT			BLOWERS	FILTER ZSIZE
UNIT SIZE	LENGTH	HEIGHT	DEPTH	A	B	C		
002-003	47	11.38	24	18.25	6.38	14.38	1	(2) 11 x 20 x 1
MM	1193.80	289.05	609.60	463.55	162.05	365.25		
004	47	11.38	24	24.25	6.38	11.378	2	(2) 11 x 20 x 1
MM	94.00	22.76	48.00	48.50	12.76	22.76		
006	55	11.38	28	32.25	6.38	11.38	2	(2) 11 x 24 x 1
MM	1397.00	289.05	711.20	819.15	162.05	289.05		
008	55	13.13	28	32.25	8	11.38	2	(2) 11 x 24 x 1
MM	1397.00	333.50	711.20	819.15	203.20	289.05		
010	69	13.13	28	38.25	8	15.38	2	(2) 11 x 27 x 1
MM	1752.60	222.50	711.20	971.55	203.20	390.65		
012	69	13.13	28	46.25	8	11.38	2	(2) 11 x 27 x 1
MM	1752.60	333.50	711.20	1174.75	203.20	289.05		

- Right hand unit shown, left hand unit opposite.
- Coil connections determined by facing the supply air opening.
- Electrical junction box is located on the same side as the coil connections.
- Unit must be installed level and condensate drain lines should be trapped.
- Drain pan is powder coated epoxy with a 1/8" thick Elastomeric insulation and has 3/4" NPT primary and secondary drain connections.
- Entire cabinet, scroll and blower wheel are heavy gauge, galvanized steel.
- Coil connections: 1/2" CW and HW on 002-003.