

TOP VIEW

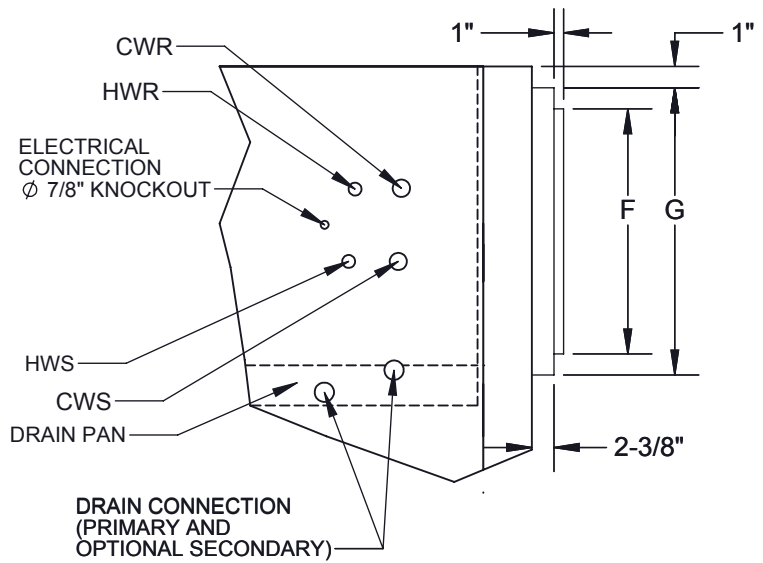

COIL CONNECTION DETAIL

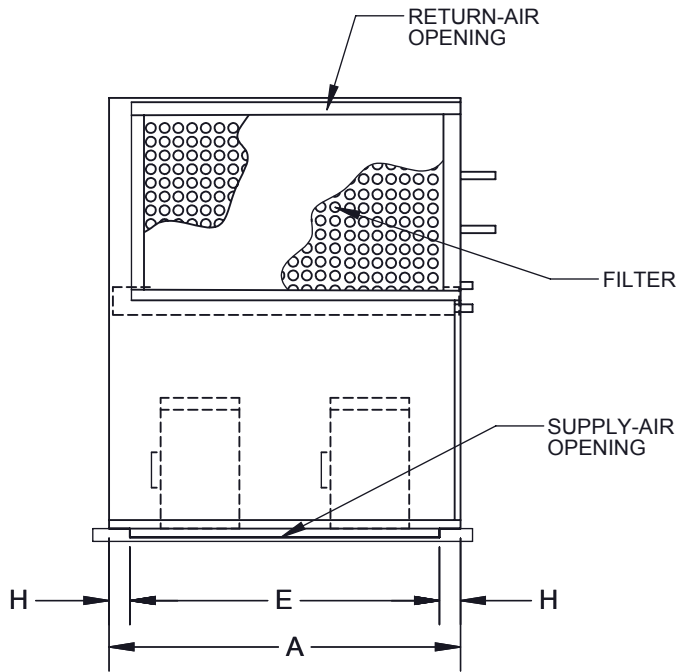

FRONT VIEW

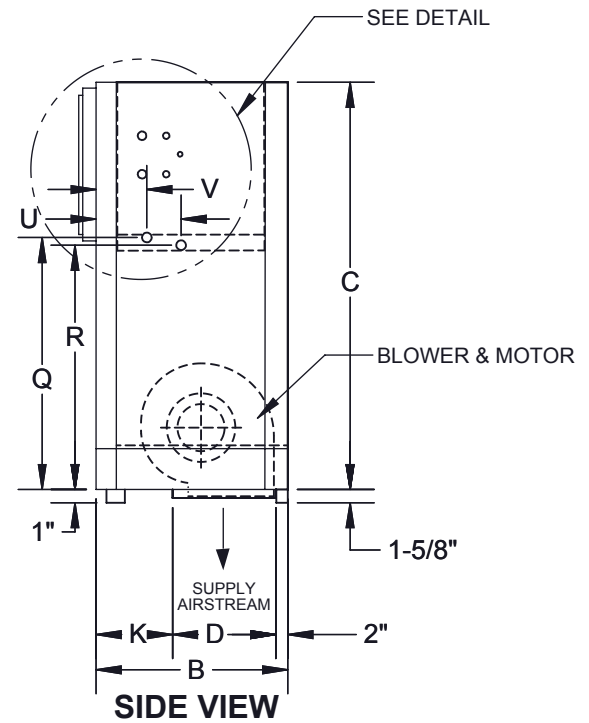

SIDE VIEW

RIGHT HAND UNIT SHOWN

MODEL	A	B	C	D	E	F	G	H	J	K	L	M	N	Q	R	U	V	Blower/Motor	Filter Size
004-006	24-1/16	27-1/8	46	14	20	17-1/2	20	2-1/32	18	11-1/8	1	26	20-1/4	28-11/16	27-1/2	12	8	1	(1) 16x20x1
008	24-1/16	27-1/8	46	14	20	17-1/2	20	2-1/32	18	11-1/8	1	26	20-1/4	28-11/16	27-1/2	12	8	1	(1) 16x20x1
010	30-1/16	27-1/8	46	14	20	17-1/2	20	5-1/32	23	11-1/8	1	32	20-1/4	28-11/16	27-1/2	12	8	1	(1) 20x20x1
012	30-1/16	27-1/8	46	14	20	17-1/2	20	5-1/32	23	11-1/8	1	32	20-1/4	28-11/16	27-1/2	12	8	1	(1) 20x25x1
015	38-1/16	27-1/8	46	16	22	17-1/2	20	8-1/32	29-11/16	9-1/8	1-3/8	40	20-1/4	28-11/16	27-1/2	12	8	2	(2) 16x20x1
018	38-1/16	27-1/8	54	18	24	17-1/2	20	7-1/16	29-11/16	7-1/8	1-3/8	40	20-1/4	34-5/16	33-1/8	12-1/8	8-1/8	2	(2) 16x20x1
022	46-18	27-1/4	60	20	30	22-9/16	25	8-1/8	37-11/16	5-1/4	1-3/8	48	20-1/2	34-5/16	32-1/16	12-1/8	8-1/8	2	(1) 16x20x1 (1) 20x20x1

C2-G/C2-Q
REV A

D107778

- Coil connections determined by facing the supply-air opening.
- Electrical junction box is located on the same side as the coil connections.
- Unit must be installed level and condensate drain lines should be trapped.