

HIGH PERFORMANCE CASED VERTICAL

C2-B/D CASED CLOSET BASIC BOTTOM RETURN

400 - 800 CFM

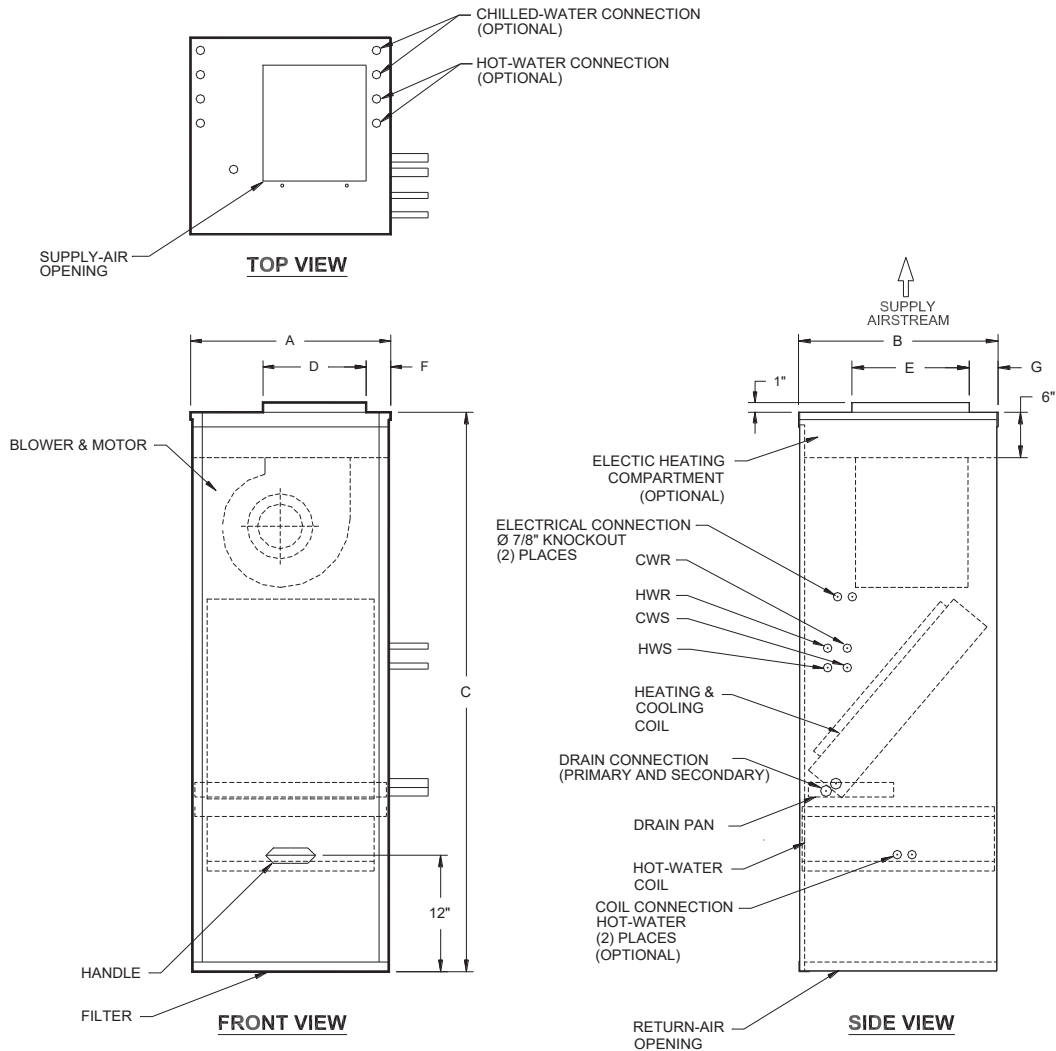

MODEL CV-B/D	A	B	C	D	E	F	G	FILTER SIZE
400	20-5/32	14-5/32	57-5/8	10-15/32	7-3/32	2-7/32	3-1/32	16 X 16 X 1
600	20-5/32	14-5/32	57-5/8	10-15/32	8-15/32	2-7/32	3-1/32	16 X 20 X 1
800	20-5/32	14-5/32	57-5/8	10-15/32	9-13/32	2-7/32	3-1/32	20 X 20 X 1

- Right hand unit shown, left hand unit opposite.
- Coil connections determined by facing the front access panel.
- Electrical junction box is located on the same side as the coil connections.
- Unit must be installed level and condensate drain lines should be trapped.
- Drain pan is powder coated epoxy with a 1/8" thick closed-cell insulation and has 3/4" NPT, primary and secondary drain connections.

HIGH PERFORMANCE CASED VERTICAL

C2-B/D CASED CLOSET BASIC BOTTOM RETURN

1,000 - 2,200 CFM

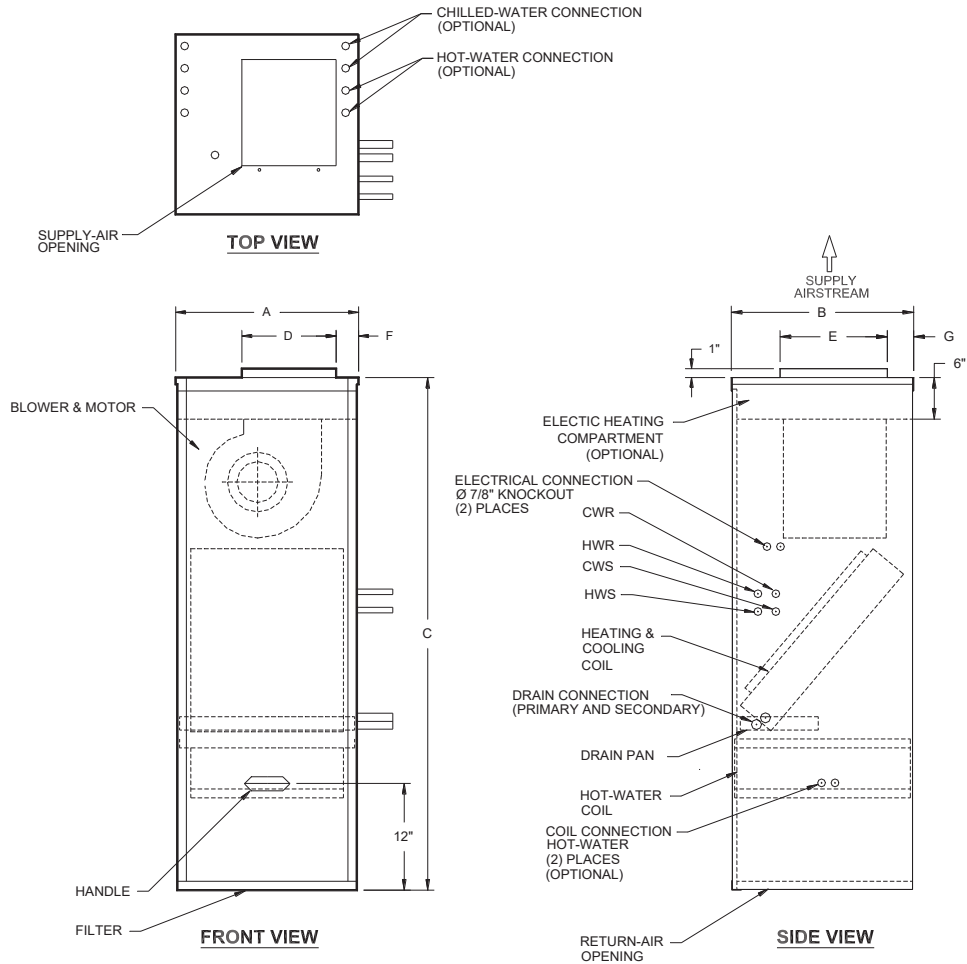

MODEL CV-B/D	A	B	C	D	E	F	G	FILTER SIZE
1000	20-3/8	20-3/8	57-3/8	10-3/8	12	2-3/8	3-1/16	20 x 20 x 1
1200	20-3/8	20-3/8	57-3/8	10-3/8	12	2-3/8	3-1/16	20 x 20 x 1
1500	36	24-5/8	62-3/4	10-1/2	24	3	3	30 x 24 x 1
1800	36	24-5/8	62-3/4	10-1/2	24	3	3	30 x 24 x 1
2200	36	24-5/8	62-3/4	10-1/2	24	3	3	30 x 24 x 1

- Right hand unit shown, left hand unit opposite.
- Coil connections determined by facing the front access panel.
- Electrical junction box is located on the same side as the coil connections.
- Unit must be installed level and condensate drain lines should be trapped.
- Drain pan is powder coated epoxy with a 1/8" thick closed-cell insulation and has 3/4" NPT, primary and secondary drain connections.
- Entire cabinet, scroll and blower wheel are heavy gauge, galvanized steel.
- Coil connections: 1/2" CW on CV010, 3/4" on CV012-022 and 1/2" HW on CV010-022.